

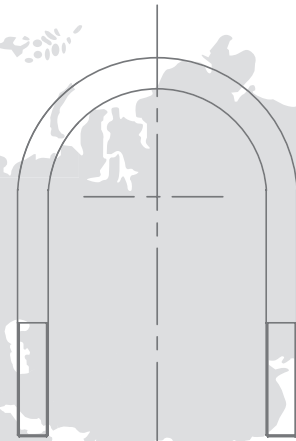

SYNERGY STEELS LTD

STAINLESS STEEL FASTENERS

WHEN 100 %
RELIABILITY IS
MUST

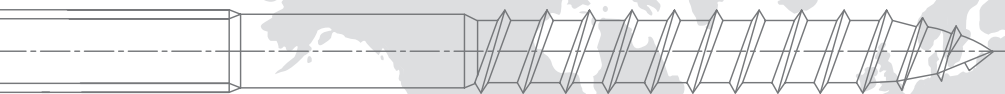
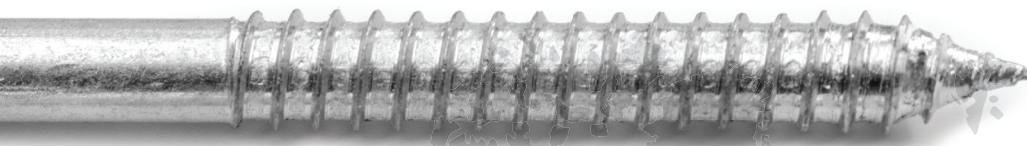
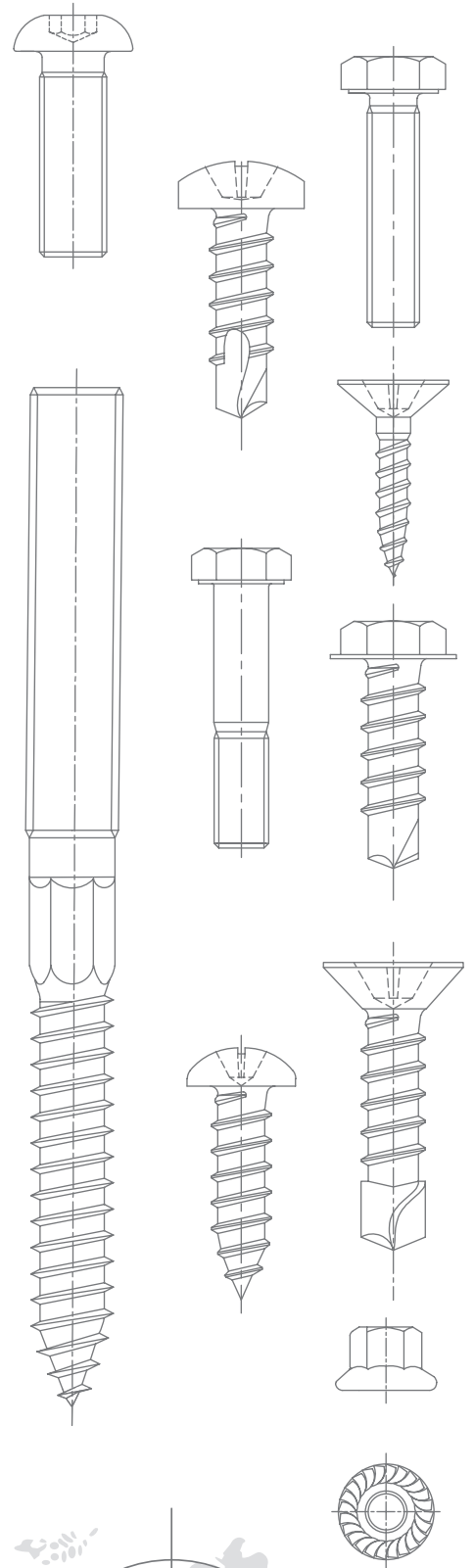

INTEGRATED STAINLESS EXPERTISE

Expect the world from us. Synergy Steels is perhaps one of the handful of integrated manufacturers of stainless steel long products in India.

STAINLESS STEEL
MANUFACTURING



20 YEARS
EXPERIENCE

DEPTH OF
KNOWLEDGE



WORLD CLASS
PLANT

FROM METAL
TO PRODUCTS



ECONOMY
OF SCALE



SYNERGY STEELS - INTEGRATING THE LONGEST VALUE CHAIN IN STAINLESS STEEL

Synergy Steels is a prominent player in the Indian stainless steel industry, produces high-quality stainless steel long products at extremely competitive costs.

AT A GLANCE



CAPACITY

2,50,000 TPA of Stainless Steel



PRODUCTS

Stainless Steel Billets, Flats, Wire Rods, Round Bars, Bright Bars, Stainless Steel Wires, Fasteners

Stainless Steel Long Products

Synergy Steels, an internationally recognized name in the stainless steel, manufactures long products — high quality flats, wire rods, bright bars and wire with an existing annual melting capacity of 250,000 tons. Our products find diverse use in a wide range of applications across industries all over the world.

Backed by an integrated production chain, Synergy Steels has established an international presence providing unlimited value to its customers worldwide.

At Synergy Steels, our belief of leadership stems from an exemplary performance. We have always strived to set standards that go beyond industry norms. We are innovating and improving our offerings and provide products tailor-made for our domestic and international customers.

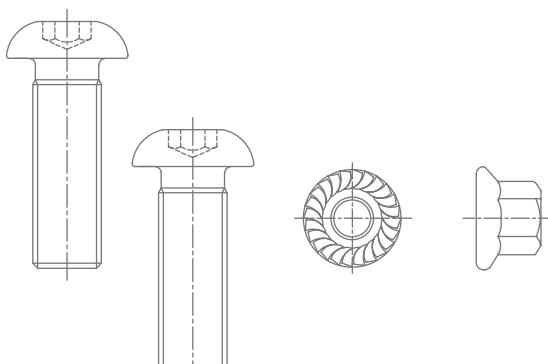
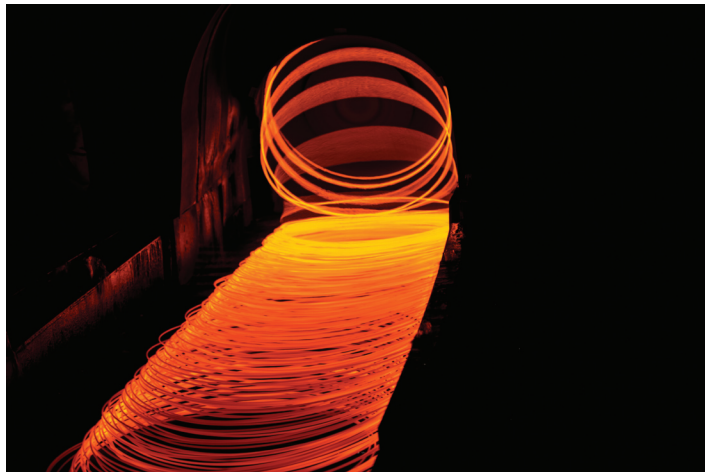

FASTENER DIVISION

Having a fully integrated operations will give a precise control over the complete manufacturing process - right from making of the stainless steel to the finished fasteners. What you will get are advantages of the large economies of scale and a world class product at a highly competitive price.

As a part of a long-term strategic forward integration plan, Synergy Steels is now setting up a state-of-the-art facility for fastener manufacturing in Rajasthan, India.

This facility will produce 1500 metric tons of fasteners monthly by August 2023 and will expand progressively further to reach the manufacturing of 4000 tons monthly by 2026.

The stainless steel fastener vertical of Synergy Steels offers high quality ergonomically designed stainless steel fasteners, screws, nuts, washers etc. manufactured to international standards.

In the new plant being set up, what our customers' expect and will get is the advantage of our long experience in stainless steel. Our effort always has been to provide the best quality products at the best price.

- Experience of more than 20 years in Stainless Steel production and related industries.
- Strong technical know-how & financials.

FASTENER MAKING

- Maximum usage of wire rods for less labour Involvement.
- Advanced operation centers for forging, machining and threading, tapping and sorting for the best product
- Scrupulous quality assurance department, along with in-house designing to meet the ever demanding requirement of industry.

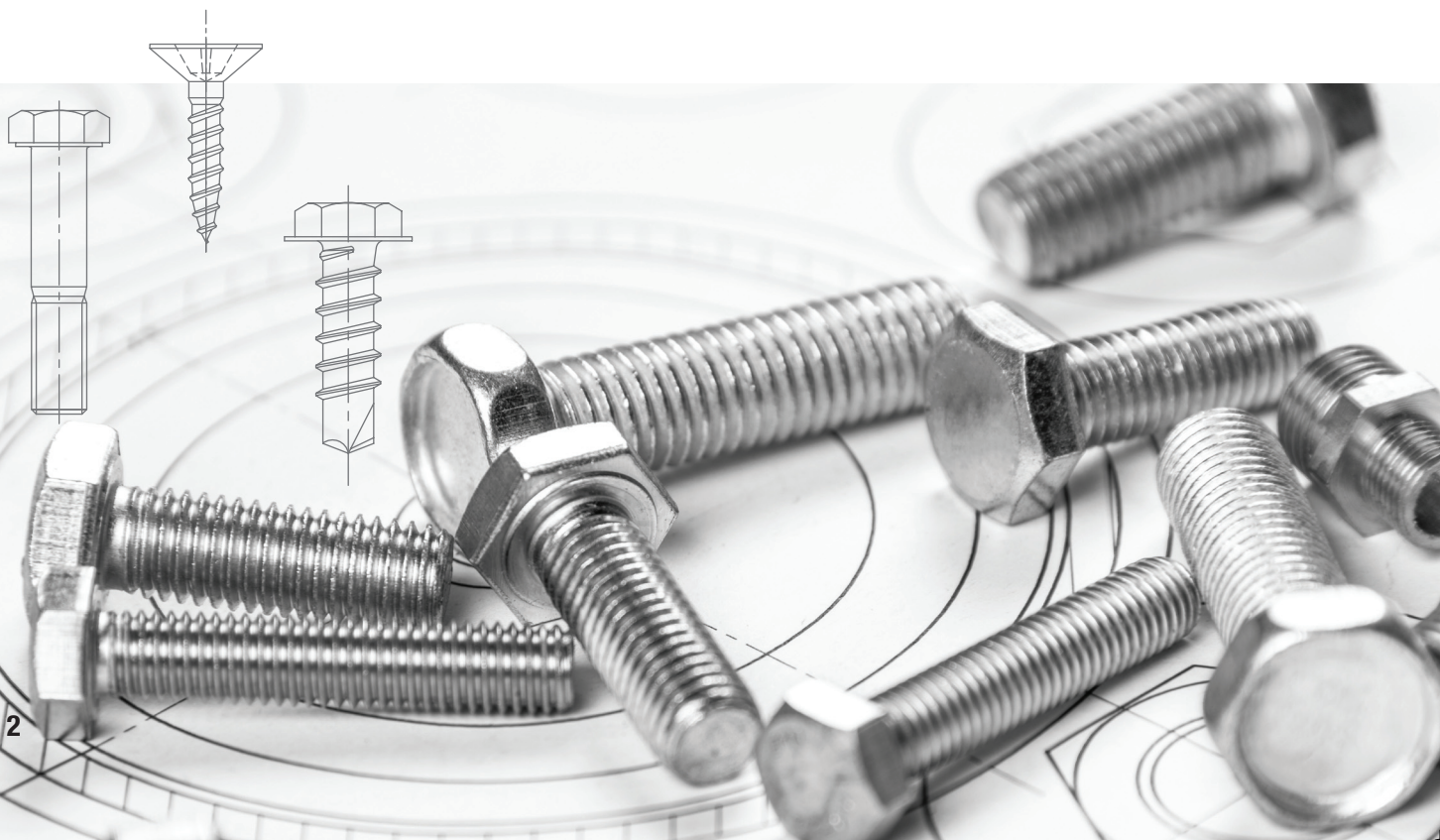

IN-HOUSE DESIGN

Whether it is a quest for improved and efficient designs or finding better ways of riveting, you can trust our team to deliver products that enhance the overall experience.

The in-house production of stainless steel raw material is an added advantage for the development of special items. Specifications of A4-100, A5, and A5-70, apart from standard grade A2 and A4 in tensile of 700 N/mm² and 800 N/mm² are being manufactured.

The R&D facility is working on the development of steel & manufacturing capability of serving 1000 N/mm² grade of fasteners in stainless steel.



With total QMS at the shop floor, Synergy Steels is also in the process of acquiring TUV 9001, PED, and ADW2000 certification to meet the industry requirement.

Supported by an exceptional quality lab, inspection line and digital measuring systems, continuous training program for employees will ensure that every process goes through a thorough scrutiny.

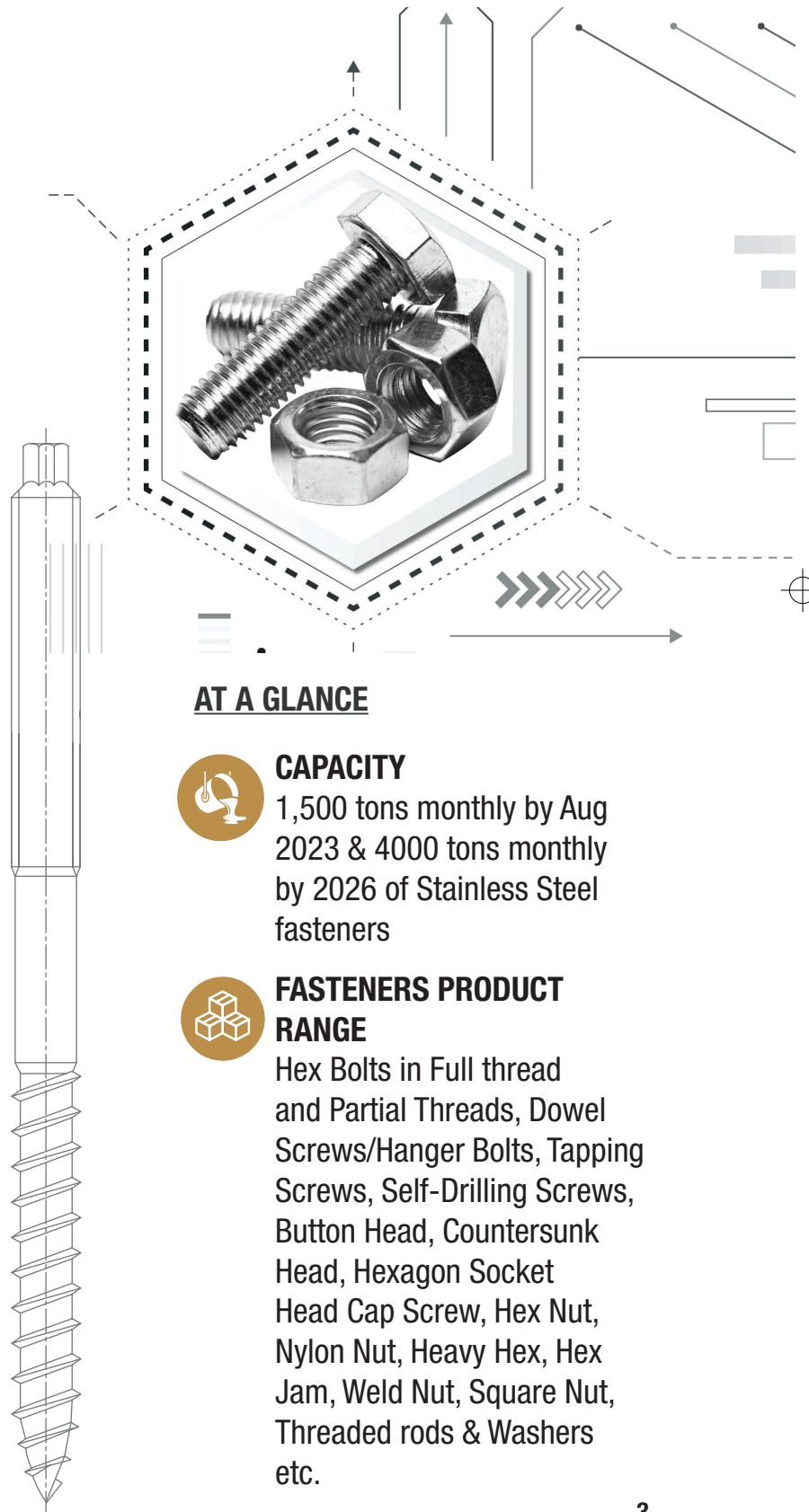
Synergy Steels fastener's product range covers hex bolts in full and partial threads, dowel screw/hanger bolts, tapping screws, self-drilling screw, button heads, countersunk heads, hexagon socket head cap screws, hex nuts, nylon nuts, heavy hexs, hex jams, weld nuts, square nuts, threaded rods & washers etc.



AT A GLANCE

-  **CAPACITY**
1,500 tons monthly by Aug 2023 & 4000 tons monthly by 2026 of Stainless Steel fasteners
-  **FASTENERS PRODUCT RANGE**
Hex Bolts in Full thread and Partial Threads, Dowel Screws/Hanger Bolts, Tapping Screws, Self-Drilling Screws, Button Head, Countersunk Head, Hexagon Socket Head Cap Screw, Hex Nut, Nylon Nut, Heavy Hex, Hex Jam, Weld Nut, Square Nut, Threaded rods & Washers etc.

TECHNICAL SPECIFICATIONS

HEXAGON SOCKET HEAD CAP SCREWS-DIN912/ ISO4762 FULL THREAD

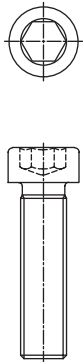

DIA	LENGTH
M5	8mm-80mm
M6	10mm-150mm
M8	10mm-150mm
M10	16mm-200mm
M12	20mm-200mm
M14	30mm-200mm
M16	30mm-200mm
M18	35mm-200mm
M20	35mm-200mm
M22*	40mm-200mm
M24*	50mm-200mm
M27*	50mm-200mm

HEXAGON SOCKET HEAD CAP SCREWS-ASME 18.3 FULL THREAD

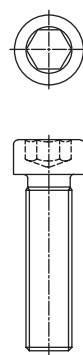

DIA	LENGTH
1/4"	3/8" to 6"
5/16"	3/8" to 6"
3/8"	1/2" to 8"
7/16"	1" to 8"
1/2"	1" to 8"
5/8"	1-1/4" to 8"
3/4"	1-1/2" to 8"
7/8" *	1-3/4" to 8"
1" *	2" to 8"
1-1/4" *	2" to 8"

HEXAGON SOCKET HEAD CAP SCREWS-DIN912/ ISO4762 PARTIAL THREAD

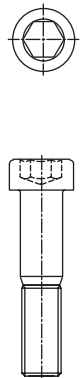

DIA	LENGTH
M5	30mm-80mm
M6	35mm-200mm
M8	40mm-250mm
M10	45mm-250mm
M12	55mm-250mm
M14	60mm-200mm
M16	65mm-200mm
M18	70mm-200mm
M20	75mm-200mm
M22 *	75mm-250mm
M24 *	85mm-250mm

HEXAGON SOCKET HEAD CAP SCREWS-ASME 18.3 PARTIAL THREAD

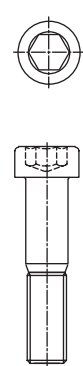

DIA	LENGTH
1/4"	1-1/2" to 8"
5/16"	1-3/4" to 10"
3/8"	1-3/4" to 10"
7/16"	2" to 10"
1/2"	2" to 10"
5/8"	2-1/2" to 8"
3/4"	3" to 8"
7/8" *	3" to 8"
1" *	3-1/2" to 10"

HEXAGON SOCKET HEAD CAP SCREWS WITH LOW HEAD-DIN7984

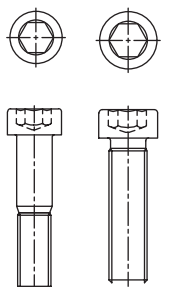

Partial Thread Full Thread

DIA	LENGTH
M5	10mm-60mm
M6	10mm-70mm
M8	12mm-vmmm
M10	16mm-120mm
M12	20mm-120mm
M14	30mm-120mm
M16	30mm-120mm
M20	40mm-120mm

SOCKET HEAD CAP SCREWS WITH CENTER HOLE LOW HEAD-DIN6912

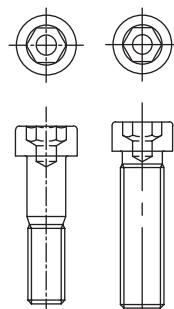

Partial Thread Full Thread

DIA	LENGTH
M5	10mm-60mm
M6	10mm-70mm
M8	12mm-80mm
M10	16mm-90mm
M12	20mm-100mm
M14	20mm-120mm
M16	30mm-120mm
M18	35mm-150mm

**COUNTERSUNK HEAD/FLAT SOCKET SCREWS-
DIN7991/ISO10642 FULL THREAD**

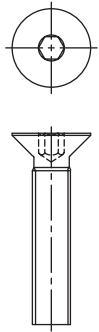

DIA	LENGTH
M3	8mm-40mm
M4	8mm-40mm
M5	8mm-70mm
M6	8mm-100mm
M8	10mm-100mm
M10	16mm-200mm
M12	20mm-200mm
M14	25mm-200mm
M16	30mm-200mm
M18	35mm-200mm
M20	35mm-200mm
M22 *	40mm-200mm
M24 *	50mm-200mm

**COUNTERSUNK HEAD/FLAT SOCKET SCREWS-
ASME 18.3 FULL THREAD**

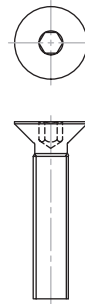

DIA	LENGTH
1/4"	3/8" to 4"
5/16"	3/8" to 4"
3/8"	3/4" to 8"
1/2"	1" to 8"
5/8"	1-1/4" to 8"
3/4"	1-1/2" to 8"
7/8" *	1-3/4" to 8"
1" *	2" to 8"

**COUNTERSUNK HEAD/FLAT SOCKET SCREWS-
DIN7991/ISO10642 PARTIAL THREAD**

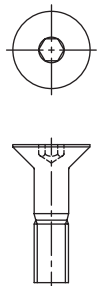

DIA	LENGTH
M3	25mm-40mm
M4	30mm-40mm
M5	35mm-70mm
M6	40mm-100mm
M8	50mm-100mm
M10	50mm-200mm
M12	60mm-200mm
M14	60mm-200mm
M16	70mm-200mm
M18	70mm-200mm
M20	80mm-200mm
M22 *	90mm-250mm*
M24 *	100mm-250mm*

**COUNTERSUNK HEAD/FLAT SOCKET SCREWS-
ASME 18.3 PARTIAL THREAD**

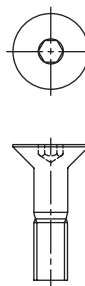

DIA	LENGTH
1/4"	1-3/4" to 4"
5/16"	2" to 4"
3/8"	2" to 8"
1/2"	2-3/8" to 8"
5/8"	3" to 8"
3/4"	3-1/4" to 8"
7/8" *	4" to 10"
1" *	4" to 10"

**RAISED(OVAL) COUNTERSUNK HEAD TAPPING
SCREWS-DIN7983/ISO7051**

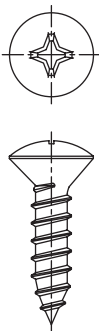

DIA	LENGTH
ST2.9	6.5mm-25mm
ST3.5	9.5mm-38mm
ST3.9	9.5mm-45mm
ST4.2	9.5mm-45mm
ST4.8	9.5mm-45mm
ST5.5	13mm-45mm
ST6.3	13mm-45mm

HEXAGON HEAD TAPPING SCREWS-DIN7976



DIA	LENGTH
ST2.9	9.5mm-19mm
ST3.5	9.5mm-25mm
ST3.9	9.5mm-25mm
ST4.2	9.5mm-32mm
ST4.8	9.5mm-50mm
ST5.5	13mm-50mm
ST6.3	13mm-50mm

BUTTON HEAD SCREW-ISO7380-1 FULL THREAD

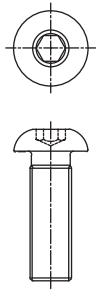

DIA	LENGTH
M3	8mm-40mm
M4	8mm-40mm
M5	8mm-70mm
M6	8mm-100mm
M8	10mm-100mm
M10	16mm-200mm
M12	20mm-200mm

BUTTON HEAD SCREW-ASME 18.3 FULL THREAD

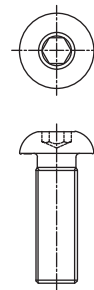

DIA	LENGTH
1/4"	3/8" to 4"
5/16"	3/8" to 4"
3/8"	3/4" to 8"
1/2"	1" to 8"

FLANGE BUTTON HEAD SCREW-ISO7380-2 FULL THREAD

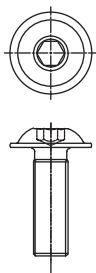

DIA	LENGTH
M3	8mm-40mm
M4	8mm-40mm
M5	8mm-70mm
M6	8mm-100mm
M8	10mm-100mm
M10	16mm-200mm
M12	20mm-200mm

FLANGE BUTTON HEAD SCREW-ASME 18.3 FULL THREAD

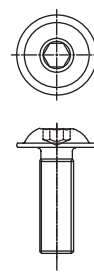

DIA	LENGTH
1/4"	3/8" to 4"
5/16"	3/8" to 4"
3/8"	3/4" to 8"
1/2"	1" to 8"

PAN HEAD TAPPING SCREWS-DIN 7981 /ISO7049



DIA	LENGTH
ST2.9	6.5mm-38mm
ST3.5	6.5mm-38mm
ST3.9	6.5mm-45mm
ST4.2	9.5mm-45mm
ST4.8	9.5mm-45mm
ST5.5	13mm-45mm
ST6.3	13mm-45mm

COUNTERSUNK HEAD TAPPING SCREWS-DIN7982/ISO7050

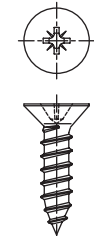

DIA	LENGTH
ST2.9	6.5mm-38mm
ST3.5	6.5mm-38mm
ST3.9	9.5mm-45mm
ST4.2	9.5mm-50mm
ST4.8	9.5mm-50mm
ST5.5	13mm-50mm
ST6.3	13mm-50mm

SLOTTED PAN HEAD TAPPING SCREWS-DIN7981/ISO1481



DIA	LENGTH
ST2.9	6.5mm-22mm
ST3.5	9.5mm-25mm
ST3.9	9.5mm-25mm
ST4.2	9.5mm-32mm
ST4.8	9.5mm-38mm
ST5.5	13mm-38mm
ST6.3	13mm-38mm

SLOTTED COUNTERSUNK HEAD TAPPING SCREWS-DIN7972/ISO1482

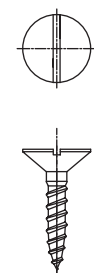

DIA	LENGTH
ST2.9	6.5mm-19mm
ST3.5	9.5mm-25mm
ST3.9	9.5mm-25mm
ST4.2	9.5mm-32mm
ST4.8	9.5mm-38mm
ST5.5	13mm-38mm
ST6.3	13mm-38mm

SLOTTED RAISED(OVAL) COUNTERSUNK HEAD TAPPING SCREWS-DIN7973/ISO1483



DIA	LENGTH
ST2.9	6.5mm-19mm
ST3.5	9.5mm-25mm
ST3.9	9.5mm-25mm
ST4.2	9.5mm-32mm
ST4.8	9.5mm-38mm
ST5.5	13mm-38mm
ST6.3	13mm-38mm

SELF DRILLING SCREWS WITH COUNTERSUNK HEAD TYPE O-DIN7504/ISO14582



DIA	LENGTH
ST3.5	16mm-25mm
ST3.9	16mm-38mm
ST4.2	16mm-38mm
ST4.8	16mm-50mm

SELF DRILLING SCREWS HEXAGON FLANGE HEAD TYPE K-DIN7504/ISO15480



DIA	LENGTH
ST3.5	6.5mm-25mm
ST3.9	6.5mm-50mm
ST4.2	9.5mm-50mm
ST4.8	9.5mm-75mm
ST5.5	13mm-120mm
ST6.3	13mm-120mm

SELF DRILLING SCREWS WITH PAN HEAD TYPE M-DIN7504/ISO14581



DIA	LENGTH
ST3.5	13mm-25mm
ST3.9	13mm-38mm
ST4.2	13mm-38mm
ST4.8	13mm-50mm

COUNTERSUNK HEAD WOOD SCREWS-DIN7997

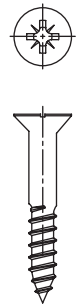

DIA	LENGTH
M3	10mm-40mm
M3.5	10mm-45mm
M4	12mm-60mm
M4.5	16mm-60mm
M5	16mm-80mm
M6	20mm-80mm

RAISED COUNTERSUNK HEAD WOOD SCREWS-DIN7995



DIA	LENGTH
M3	10mm-40mm
M3.5	10mm-45mm
M4	12mm-50mm
M4.5	16mm-60mm
M5	16mm-80mm
M6	35mm-80mm

ROUND HEAD WOOD SCREWS-DIN7996

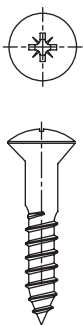

DIA	LENGTH
M3	10mm-40mm
M3.5	10mm-45mm
M4	12mm-50mm
M4.5	16mm-60mm
M5	16mm-80mm
M6	40mm-80mm

SLOTTED COUNTERSUNK HEAD WOOD SCREWS-DIN97



DIA	LENGTH
M3	10mm-40mm
M3.5	10mm-60mm
M4	12mm-60mm
M4.5	16mm-60mm
M5	16mm-80mm
M6	20mm-150mm

SLOTTED RAISED COUNTERSUNK HEAD WOOD SCREWS-DIN95



DIA	LENGTH
M3	10mm-40mm
M3.5	10mm-60mm
M4	12mm-60mm
M4.5	16mm-60mm
M5	16mm-80mm
M6	40mm-80mm

SLOTTED ROUND HEAD WOOD SCREWS-DIN96



DIA	LENGTH
M3	10mm-40mm
M3.5	10mm-60mm
M4	12mm-60mm
M4.5	16mm-60mm
M5	16mm-70mm
M6	20mm-80mm

CROSS RECESSED COUNTERSUNK HEAD SCREWS-DIN965/ISO7046

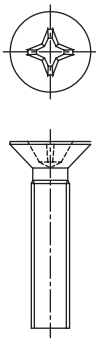

DIA	LENGTH
M3	6mm-30mm
M3.5	6mm-35mm
M4	6mm-40mm
M5	6mm-45mm
M6	8mm-45mm
M8	10mm-55mm
M10	12mm-60mm

CROSS RECESSED COUNTERSUNK HEAD SCREWS-ASME 18.6.3

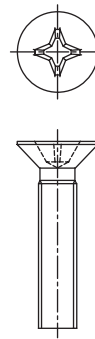

DIA	LENGTH
#6	1/4" to 1"
#8	1/4" to 1-3/8"
#12	1/4" to 1-3/4"
1/4"	3/8" to 1-3/4"
5/16"	3/8" to 2"
3/8"	1/2" to 2-3/8"

CROSS RECESSED RAISED/OVAL COUNTERSUNK HEAD SCREWS-DIN966/ISO7047



DIA	LENGTH
M3	6mm-30mm
M3.5	6mm-35mm
M4	6mm-40mm
M5	6mm-50mm
M6	8mm-50mm
M8	10mm-55mm
M10	12mm-60mm

CROSS RECESSED RAISED/OVAL COUNTERSUNK HEAD SCREWS-ASME 18.6.3



DIA	LENGTH
#6	1/4" to 1"
#8	1/4" to 1-3/8"
#12	1/4" to 1-3/4"
1/4"	3/8" to 1-3/4"
5/16"	3/8" to 2"
3/8"	1/2" to 2-3/8"

SLOTTED COUNTERSUNK HEAD SCREWS-DIN963/ISO2009



DIA	LENGTH
M3	6mm-30mm
M3.5	6mm-35mm
M4	6mm-40mm
M5	6mm-50mm
M6	8mm-50mm

SLOTTED RAISED COUNTERSUNK HEAD SCREWS-DIN964/ISO2010

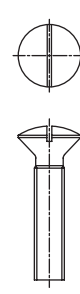

DIA	LENGTH
M3	6mm-30mm
M3.5	6mm-35mm
M4	6mm-40mm
M5	6mm-50mm
M6	8mm-50mm

SLOTTED CHEESE HEAD SCREWS-DIN84/ISO1207

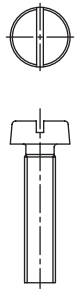

DIA	LENGTH
M3	6mm-40mm
M3.5	6mm-50mm
M4	6mm-50mm
M5	6mm-50mm
M6	8mm-50mm

SLOTTED PAN HEAD SCREWS-DIN85/ISO1580

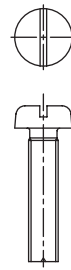

DIA	LENGTH
M3	6mm-30mm
M3.5	6mm-35mm
M4	6mm-40mm
M5	6mm-50mm
M6	8mm-60mm

COUNTERSUNK HEAD CHIPBOARD SCREW-DIN 7505 (A) FULL THREAD



DIA	LENGTH
M3	12mm-40mm
M3.5	12mm-50mm
M4	16mm-80mm
M4.5	20mm-80mm
M5	25mm-80mm
M6	25mm-110mm

SLOTTED HEADLESS SCREWS-DIN427/ISO2342

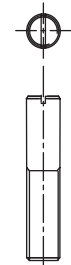

DIA	LENGTH
M3	6mm-30mm
M3.5	8mm-30mm
M4	8mm-40mm
M5	10mm-40mm
M6	12mm-40mm

HEXAGON SOCKET SET SCREWS WITH FLAT POINT-DIN913/ISO4026

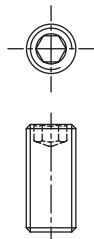

DIA	LENGTH
M5	6mm-25mm
M6	6mm-35mm
M8	8mm-40mm
M10	10mm-40mm
M12	16mm-40mm

HEXAGON SOCKET SET SCREWS WITH FLAT POINT-ASME 18.3

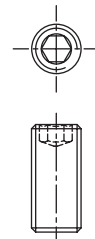

DIA	LENGTH
1/4"	5/16" to 1-3/8"
5/16"	5/16" to 1-5/8"
3/8"	1/2" to 1-5/8"
1/2"	5/8" to 1-5/8"

HEXAGON SOCKET SET SCREWS WITH CUP POINT-DIN916/ISO4029

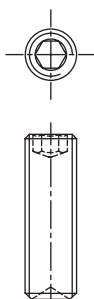

DIA	LENGTH
M5	6mm-25mm
M6	6mm-35mm
M8	8mm-40mm
M10	12mm-40mm
M12	16mm-40mm

HEXAGON SOCKET SET SCREWS WITH CUP POINT-ASME 18.6.3

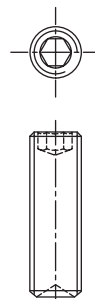

DIA	LENGTH
1/4"	5/16" to 1-3/8"
5/16"	5/16" to 1-5/8"
3/8"	1/2" to 1-5/8"
1/2"	5/8" to 1-5/8"

**SLOTTED SET SCREWS WITH CUP POINT-DIN438/
ISO7436**

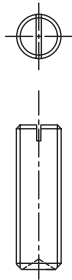

DIA	LENGTH
M3	6mm-10mm
M4	6mm-12mm
M5	6mm-16mm
M6	6mm-20mm

**SLOTTED SET SCREWS WITH FLAT POINT-DIN551/
ISO4766**

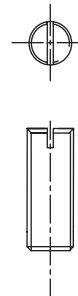

DIA	LENGTH
M3	6mm-10mm
M4	6mm-12mm
M5	6mm-16mm
M6	6mm-20mm

HEXAGON HEAD-DIN933/ISO4017 FULL THREAD

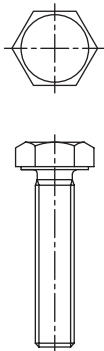

DIA	LENGTH
M5	8mm-80mm
M6	8mm-90mm
M8	10mm-200mm
M10	16mm-200mm
M12	20mm-200mm
M14	30mm-200mm
M16	30mm-200mm
M18	35mm-200mm
M20	35mm-200mm
M22*	40mm-200mm
M24*	40mm-200mm
M27*	40mm-250mm
M30*	50mm-250mm
M33*	60mm-250mm
M36*	60mm-250mm

HEXAGON HEAD-ASME 18.2.1 FULL THREAD

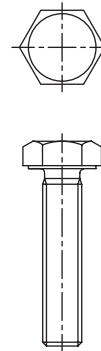

DIA	LENGTH
1/4"	5/16" to 3-1/2"
5/16"	3/8" to 8"
3/8"	5/8" to 8"
7/16"	5/8" to 8"
1/2"	3/4" to 8"
9/16"	1-1/4" to 8"
5/8"	1-1/4" to 8"
3/4"	1-1/4" to 8"
7/8" *	1-1/4" to 8"
1" *	1-1/4" to 8"
1-1/8" *	2" to 10"
1-1/4" *	2" to 10"
1-3/8" *	2-1/2" to 10"

**HEXAGON HEAD-DIN931/ISO4014
PARTIAL THREAD**

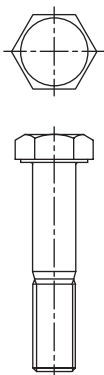

DIA	LENGTH
M5	25mm-80mm
M6	30mm-150mm
M8	35mm-250mm
M10	40mm-250mm
M12	45mm-250mm
M14	50mm-200mm
M16	55mm-200mm
M18	65mm-200mm
M20	65mm-200mm
M22*	70mm-250mm
M24*	80mm-250mm
M27*	90mm-300mm
M30*	90mm-300mm
M33*	100mm-300mm
M36*	100mm-300mm

HEXAGON HEAD-ASME 18.2.1 PARTIAL THREAD

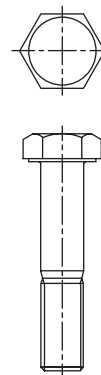

DIA	LENGTH
1/4"	1" to 6"
5/16"	1" to 10"
3/8"	1-1/2" to 10"
7/16"	1-1/2" to 10"
1/2"	1-1/2" to 10"
9/16"	2" to 8"
5/8"	2" to 8"
3/4"	2-1/4" to 8"
7/8" *	2-3/8" to 10"
1" *	2-5/8" to 10"
1-1/8" *	2-3/4" to 12"
1-1/4" *	3-1/2" to 12"
1-3/8" *	4" to 12"

**CARRIAGE BOLT/SQUARE NECK BOLT-DIN603
PARTIAL THREAD**

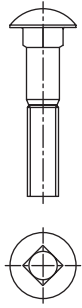

DIA	LENGTH
M5	25mm-80mm
M6	30mm-90mm
M8	35mm-110mm
M10	40mm-150mm
M12	45mm-150mm
M16	55mm-160mm

**CARRIAGE BOLT/SQUARE NECK BOLT-ASME 18.5
PARTIAL THREAD**

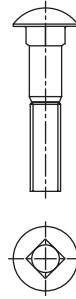

DIA	LENGTH
1/4"	1" to 3-1/2"
5/16"	1" to 4-3/8"
3/8"	1-1/2" to 6"
1/2"	1-1/2" to 6"
5/8"	2" to 6-3/8"

**CARRIAGE BOLT/SQUARE NECK BOLT-DIN603 FULL
THREAD**

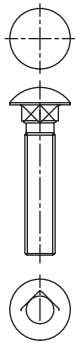

DIA	LENGTH
M5	12mm-80mm
M6	12mm-90mm
M8	12mm-110mm
M10	16mm-150mm
M12	25mm-150mm
M16	30mm-160mm

**CARRIAGE BOLT/SQUARE NECK BOLT-ASME 18.5
FULL THREAD**

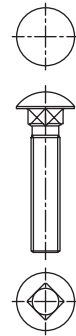

DIA	LENGTH
1/4"	1/2" to 3-1/2"
5/16"	1/2" to 4-3/8"
3/8"	5/8" to 6"
1/2"	1" to 6"
5/8"	1-3/8" to 6-3/8"

HEXAGON HEAD SCREWS WITH FLANGE-DIN6921

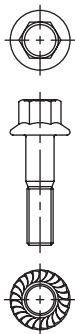

DIA	LENGTH
M6	12mm-90mm
M8	16mm-110mm
M10	20mm-150mm
M12	25mm-150mm



WOOD SCREW/LAG SCREW-DIN571

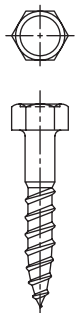

DIA	LENGTH
M5	25mm-80mm
M6	30mm-90mm
M8	35mm-110mm
M10	40mm-150mm
M12	45mm-150mm
M16	55mm-160mm

WOOD SCREW/LAG SCREW-ASME 18.2.1

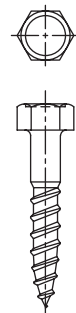

DIA	LENGTH
1/4"	1" to 3-1/2"
5/16"	1" to 4-3/8"
3/8"	1-1/2" to 6"
1/2"	1-1/2" to 6"
w5/8"	2" to 6-3/8"

HEX NUT-DIN934/ISO4032

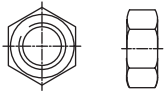

SIZE RANGE M4-M20*

HEX NUT-ASME 18.2.2



SIZE RANGE 1/4" TO 3/4"

DOMED CAP NUT-DIN1587 *

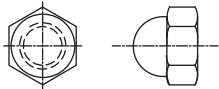

SIZE RANGE M6-M24

HEXAGON CAP NUTS-DIN917 *

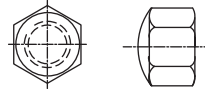

SIZE RANGE M4-M20

HEX THIN NUT-DIN439/ISO4035/DIN936



SIZE RANGE M4-M27*

HEX THIN/JAM NUT-ASME 18.2.2



SIZE RANGE 1/4"-3/4"

HEXAGON FLANGE NUTS-DIN6923



SIZE RANGE M6-M12

HEXAGON FLANGE NUTS-ASME 18.2.2



SIZE RANGE 1/4" - 1/2"

SQUARE NUT-DIN557

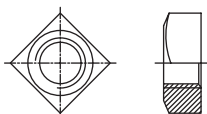

SIZE RANGE M5-M16

SQUARE NUT-ASME 18.2.2

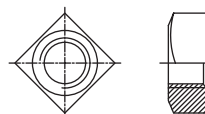

SIZE RANGE 1/4" - 5/8"

SQUARE THIN NUT-DIN562

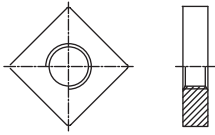

SIZE RANGE M5-M10

SQUARE THIN NUT-ASME 18.2.2

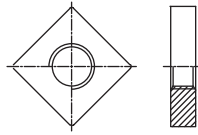

SIZE RANGE 1/4" - 3/8"

**SELF-LOCKING HEXAGON NUTS,
HIGH TYPE-DIN982/ISO7040**

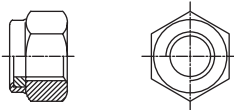

SIZE RANGE M5-M16

**SELF-LOCKING HEXAGON NUTS,
HIGH TYPE-IFI-100/107**

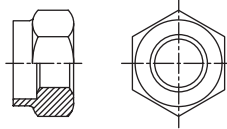

SIZE RANGE 1/4" - 1/2"

**SELF-LOCKING HEXAGON NUTS,
THIN TYPE-DIN985/ISO10511**

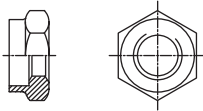

SIZE RANGE M5-M16

**SELF-LOCKING HEXAGON NUTS,
THIN TYPE-IFI-100/107**

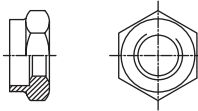

SIZE RANGE 1/4" - 1/2"

SQUARE WELD NUTS-DIN928

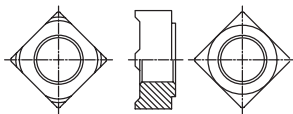

SIZE RANGE M5-M12

HEXAGON WELD NUTS-DIN929

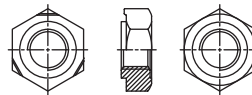

SIZE RANGE M5-M12

HEXAGON NUTS 1.5XD-DIN6330

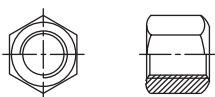

SIZE RANGE M5-M27*

HEXAGON NUTS 1.5XD WITH COLLAR-DIN6331



SIZE RANGE M5-M20
M22 - M27

HEXAGON NUTS 3XD-DIN6334



SIZE RANGE M5-M27*



STUD-DIN976/DIN975-A

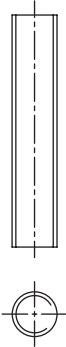

DIA	LENGTH
M5	300mm-2MTR
M6	300mm-3MTR
M8	300mm-3MTR
M10	300mm-3MTR
M12	300mm-3MTR
M14	300mm-3MTR
M16	300mm-3MTR
M18	300mm-3MTR
M20	300mm-3MTR
M22	300mm-3MTR
M24	300mm-3MTR
M27	300mm-3MTR
M30	300mm-3MTR
M33	300mm-3MTR
M36	300mm-3MTR

STUD-ASME 18.31.3/IFI 136



DIA	LENGTH
1/4"	12"-12'
5/16"	12"-12'
3/8"	12"-12'
1/2"	12"-12'
5/8"	12"-12'
3/4"	12"-12'
7/8"	12"-12'
1"	12"-12'
1-1/4"	12"-12'
1-3/8"	12"-12'
1-1/2"	12"-12'

STUD-DIN976/DIN975-B

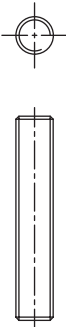

DIA	LENGTH
M6	10mm-90mm
M8	10mm-110mm
M10	10mm-150mm
M12	16mm-150mm
M14	20mm-150mm
M16	20mm-150mm
M18	25mm-150mm
M20	25mm-150mm

DOWEL SCREW/HANGER BOLT

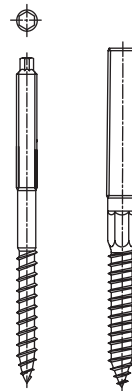

DIA	LENGTH
M6	50mm-200mm
M8	50mm-250mm
M10	60mm-300mm
M12	80mm-300mm

DOUBLE END STUD(1XD)-DIN938

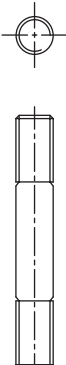

DIA	LENGTH
M5	L=16mm-120mm, b1=5
M6	L=16mm-120mm, b1=6
M8	L=16mm-200mm, b1=8
M10	L=16mm-200mm, b1=10
M12	L=16mm-200mm, b1=12
M14	L=30mm-200mm, b1=14
M16	L=30mm-200mm, b1=16

DOUBLE END STUD(1.25XD)-DIN939

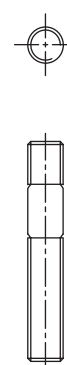

DIA	LENGTH
M5	L=16mm-120mm, b1=6.5
M6	L=16mm-120mm, b1=7.5
M8	L=16mm-200mm, b1=10
M10	L=16mm-200mm, b1=12
M12	L=16mm-200mm, b1=15
M14	L=30mm-200mm, b1=18
M16	L=30mm-200mm, b1=20

U BOLT-DIN3570-A

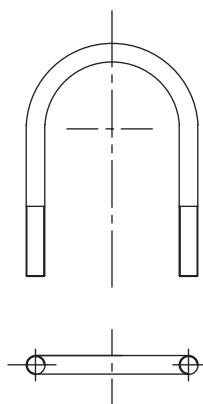

DIA	PIPE SIZE
M10	DN20 X 70 mm height
M10	DN25 X 70 mm height
M10	DN32 X 76 mm height
M10	DN40 X 86 mm height
M12	DN50 X 109 mm height
M12	DN65 X 125 mm height
M12	DN80 X 138 mm height
M16	DN100 X 171 mm height
M16	DN125 X 191 mm height
M16	DN150 X 217 mm height
M16	DN175 X 249 mm height

WASHER

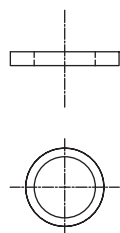

STANDARD SIZE RANGE

DIN125	M5-M16
DIN9021	M5-M16

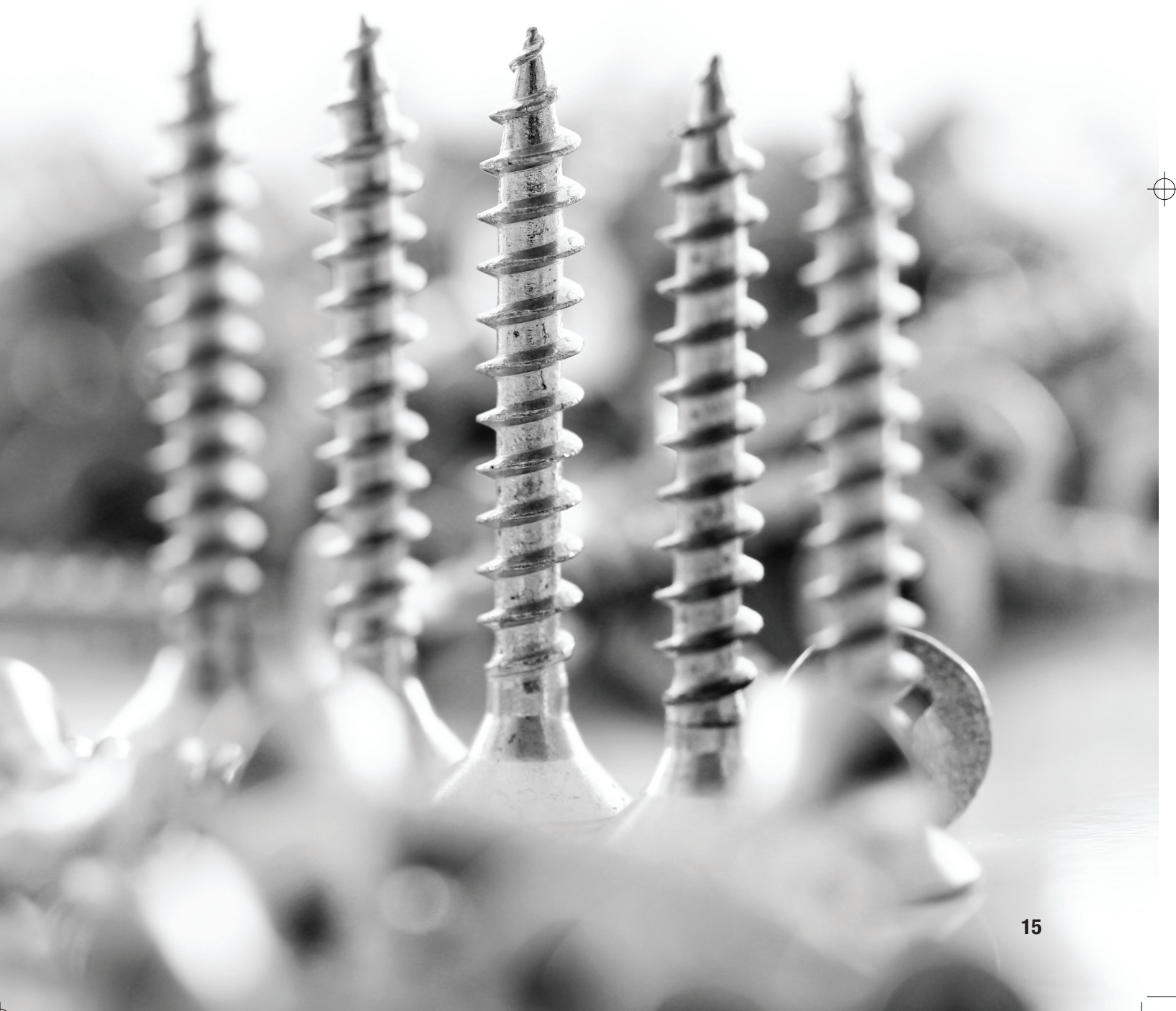

For 20 years, we have been working with our customers and partners to create long lasting solutions for the tools of modern life. You can depend on our stainless steel for reliably and for consistently meeting the specifications that your application demands.

Synergy Steels is among the leading integrated manufacturers of Stainless Steel long products in India. We create stainless steels that are efficient, long lasting, and recyclable. A strong customer focus, sustainability, and technical excellence are at the heart of everything we do.

Our customers rely on us for products that deliver the best long-term performance for their needs. All of our products are fully recyclable at the end of their life cycles.

PRODUCT RANGE





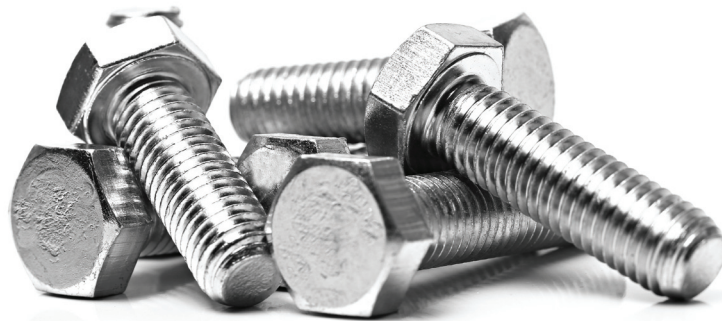

SYNERGY STEELS LTD

CORPORATE OFFICE

SYNERGY STEELS LIMITED
1/1, KIRTI NAGAR MAIN ROAD,
NEW DELHI-110015, INDIA

tel +91 11 40500500
fax +91 11 41428521
email contact@synergysteels.com
fastener1@synergysteels.com

WORKS

5, MATSYA INDUSTRIAL AREA
ALWAR, RAJASTHAN, INDIA

synergysteels.com



Process of
OHSAS
18001
Certification

